

RF26HFENDSR

25.5 cu. ft. French Door Refrigerator

Features

- Large Capacity – 25.5 cu. ft.
- High-Efficiency LED Lighting
- Twin Cooling Plus®
- Ice Maker in the Freezer
- Power Freeze and Power Cool Options
- Two Humidity-Controlled Crispers
- Tempered Glass Spill-Proof Shelves
- Gallon Door Bins
- EZ-Open Handle™ on Freezer Door
- Auto Pull-Out Upper Freezer Drawer

Convenience

- Cool Tight Door
- Door Alarm
- Removable Ice Caddy



Twin Cooling Plus



Automatic Filtered Ice Maker in the Freezer

Available Colour:



Stainless Steel

Signature Features

TWIN COOLING PLUS

- Refrigerator is kept at higher humidity levels to keep perishable fruits and vegetables fresher longer.*
- Freezer air is kept drier for less freezer burn and better tasting frozen foods.
- Fruits and veggies are no longer limited to the crispers. Produce can be placed anywhere in the fresh food compartment and retain ultimate freshness.

*When compared to Samsung fridge models that do not have Twin Cooling Plus.

ICE MAKER IN FREEZER

- Conveniently located in the freezer.

HIGH-EFFICIENCY LED LIGHTING

- High-efficiency design beautifully lights up the interior so you're able to quickly spot what you want.
- Sleek design saves more space than traditional incandescent light bulbs.



Ranked **"Highest in customer satisfaction with French Door refrigerators, in a tie."***

—J.D. Power

SAMSUNG

RF26HFENDSR

25.5 cu. ft. French Door Refrigerator

Installing Your Refrigerator

1. Measure the height, width and depth of the opening, making sure to include baseboards, moulding tile, countertop overhang, etc. Check to be sure there is enough room to open the door (consider walls, islands or other obstacles when measuring).
2. Refer to illustration below to determine dimensions.
3. Allow 2" of clearance on hinge side of refrigerator when installing next to a wall where the handle may make contact.
4. Allow 1" minimum clearance at rear for proper air circulation and water/electrical connections. Allow a 3/8" minimum clearance at sides and top for ease of installation.
5. Ensure each door and entry way in the home is wide enough for the refrigerator to be moved through easily.

Please note: The following dimension and cut-out information is for planning purposes only. For complete installation details consult manual packed with product, or download manual on-line at samsung.com.

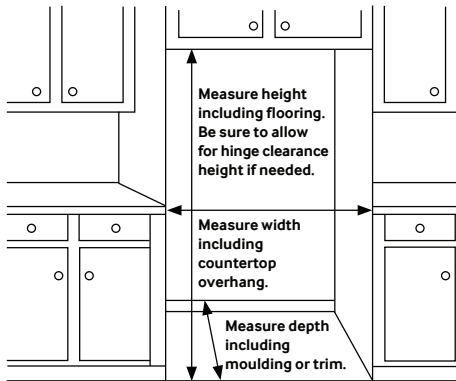

Dimensions

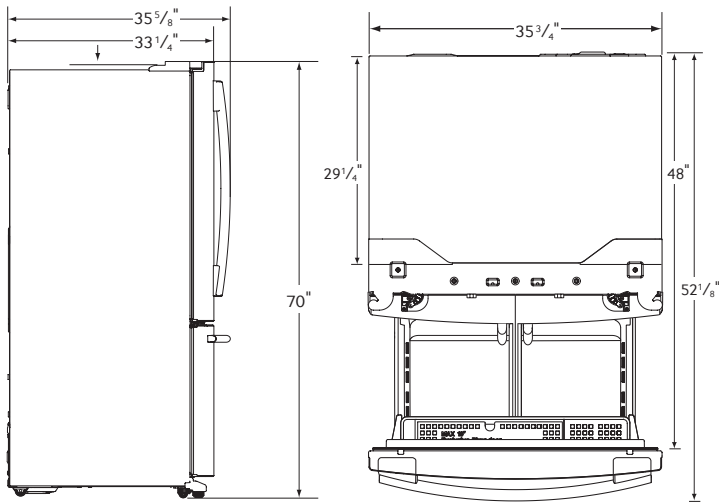

Total Capacity: 25.5 cu. ft.

Refrigerator: 17.6 cu. ft.

- 2 Humidity-Controlled Crispers
- 5 Tempered Glass Spill-Proof Shelves
- 6 Opaque Door Bins
 - Right Door: 3 Gallon Bins
 - Left Door: 3 Gallon Bins
- High-Efficiency LED Lighting

Freezer: 7.9 cu. ft.

- EZ-Open Handle
- 1 Large Opaque Bin with Divider
- Auto Pull-Out Upper Drawer
- Filtered Ice Maker (Cubed)

Accessories

External Water Filter (Not Included)

Warranty

One (1) Year Parts and Labour on Refrigerator

Five (5) Years Parts and Labour on Sealed Refrigeration System Only*

Ten (10) Years Parts and Five (5) Years Labour on Digital Inverter Compressor

*Compressor, evaporator, condenser, drier, connecting tubing

Product Dimensions & Weight

Dimensions (WxHxD with hinges, handles and doors):
35³/₄" x 70" x 35⁵/₈"

Dimensions (WxHxD without hinges and door):
35³/₄" x 68⁵/₈" x 29¹/₄"

Dimensions (WxHxD with hinge and door, no handle):
35³/₄" x 70" x 33¹/₄"

Weight: 271.2 lbs.

Shipping Dimensions & Weight (WxHxD)

Dimensions: 38⁵/₈" x 75³/₄" x 36¹/₄"

Weight: 282.2 lbs.

Colour	Model #	UPC Code
Stainless Steel	RF26HFENDSR	887276051987

SAMSUNG

Samsung received the highest numerical score for ranges/cooktops/ovens, microwaves; and french door refrigerators (3-way tie) in the proprietary J.D. Power and Associates 2014 Kitchen Appliance Study. The 2014 Kitchen Appliance Satisfaction Study is based on more than 3,200 evaluations from customers who purchased cooktops/ranges/ovens; more than 2,100 evaluations from customers who purchased over-the-range microwaves; and more than 6,400 evaluations from customers who purchased refrigerators during the past 24 months. The study was fielded from January through March 2014.

Actual colour may vary. Design, specifications, and colour availability are subject to change without notice. Non-metric weights and measurements are approximate.

© 2015 Samsung Electronics Canada Inc. All rights reserved. Samsung is a registered trademark of Samsung Electronics Co., Ltd., used with permission.